

DNSSEC for the Root Zone

NZNOG Hamilton, NZ
January 2010

Joe Abley, ICANN



**This design is the result of a cooperation
between ICANN & VeriSign with
support from the U.S. DoC NTIA**

Design

Design Requirements Keywords

Transparency

Processes and procedures should be as open as possible for the Internet community to trust the signed root

Audited

Processes and procedures should
be audited against industry standards,
e.g. ISO/IEC 27002:2005

High Security

Root system should meet all NIST
SP 800-53 technical security controls required
by a HIGH IMPACT system

Roles and Responsibilities

ICANN

IANA Functions Operator

- Manages the Key Signing Key (KSK)
- Accepts DS records from TLD operators
- Verifies and processes request
- Sends update requests to DoC for authorization and to VeriSign for implementation

DoC NTIA

U.S. Department of Commerce
National Telecommunications and Information Administration

- Authorizes changes to the root zone
 - ▶ DS records
 - ▶ Key Signing Keys
 - ▶ DNSSEC update requests follow the same process as other changes
- Checks that ICANN has followed their agreed upon verification/processing policies and procedures

VeriSign

Root Zone Maintainer

- Manages the Zone Signing Key (ZSK)
- Incorporates NTIA-authorized changes
- Signs the root zone with the ZSK
- Distributes the signed zone to the root server operators

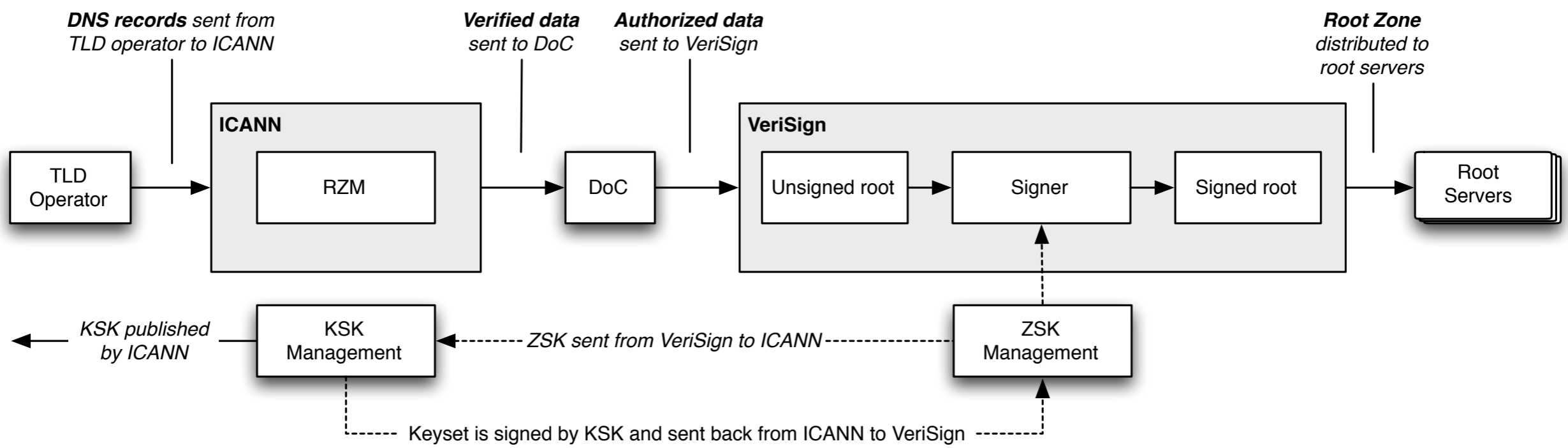

Approach to Protecting the KSK

Physical Security

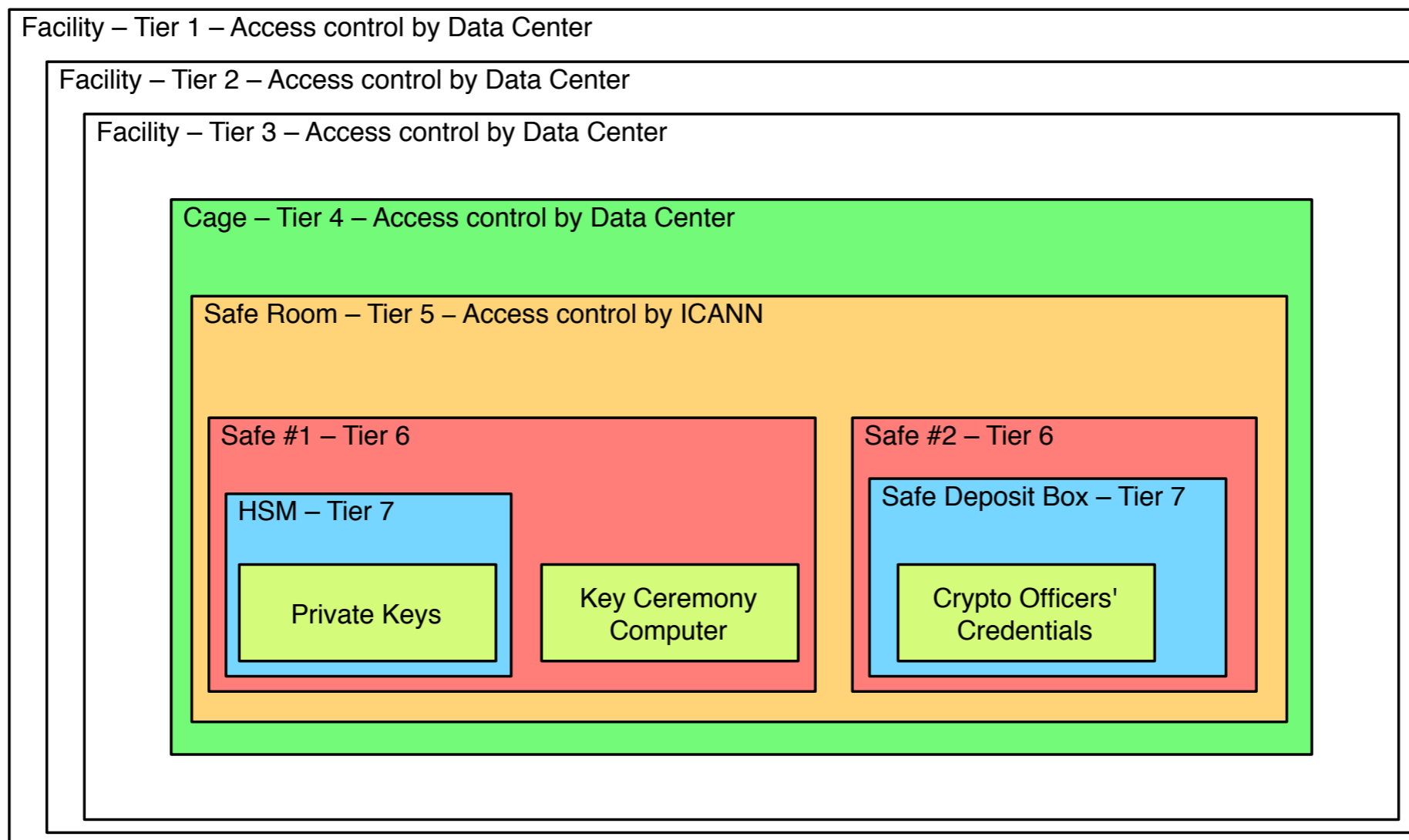

DPS

DNSSEC Practice Statement

- States the practices and provisions that are employed in root zone signing and zone distribution services
 - ▶ Issuing, managing, changing and distributing DNS keys in accordance with the specific requirements of the U.S. DoC NTIA
- Comparable to a certification practice statement (CPS) from an X.509 certification authority (CA)

Key Signing Key Management

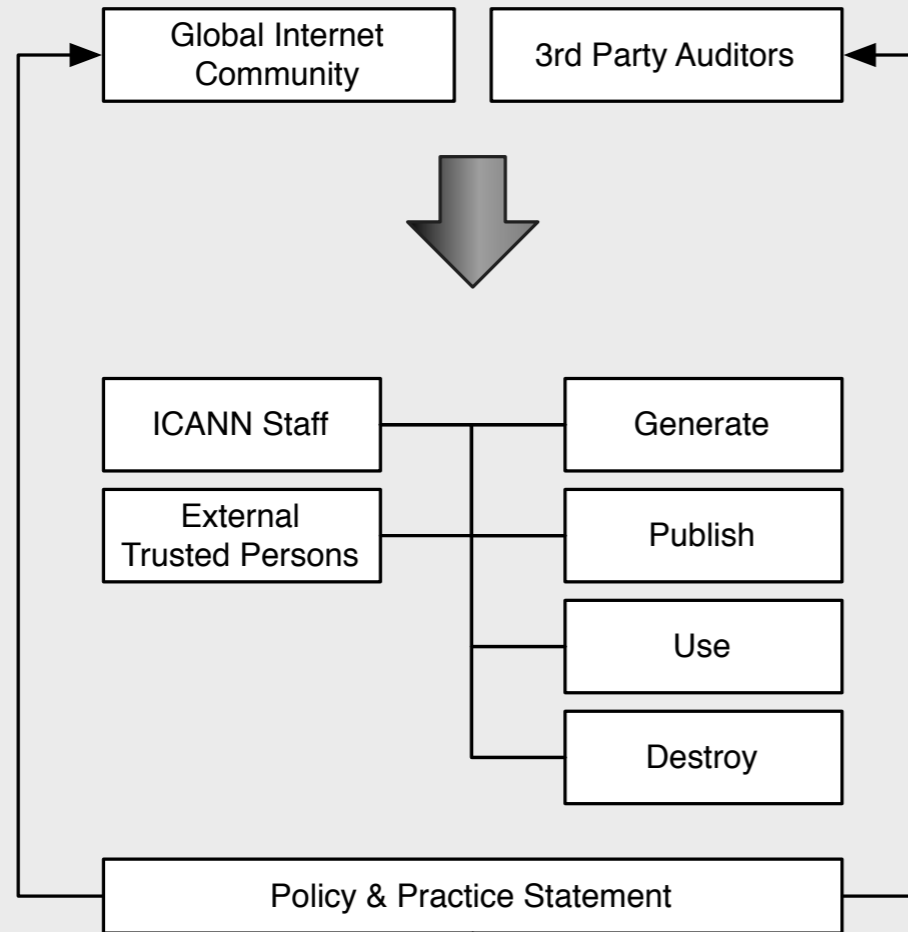

Zone Signing Key Management

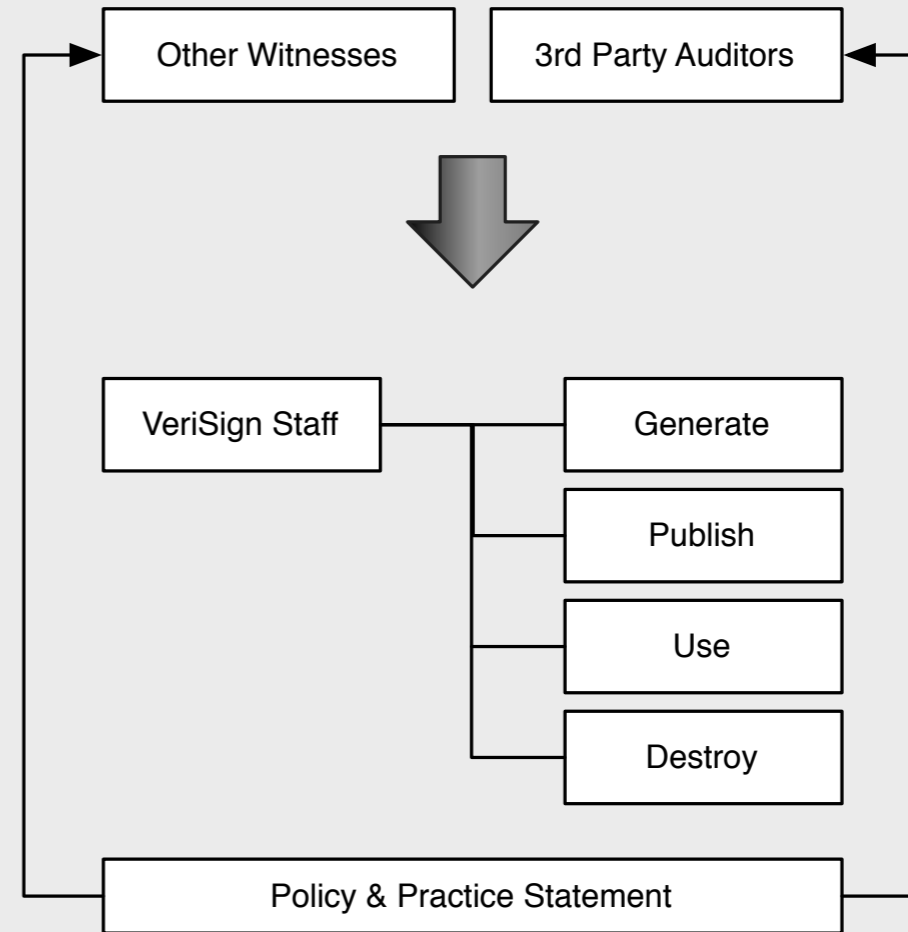

Community Trust

- Proposal that Community Trusted Representatives (TCR) have an active roll in management of the KSK
 - ▶ as Crypto Officers needed to activate the KSK
 - ▶ as Recovery Key Share Holders protecting shares of the symmetric key that encrypts the backup copy of the KSK

Crypto Officers

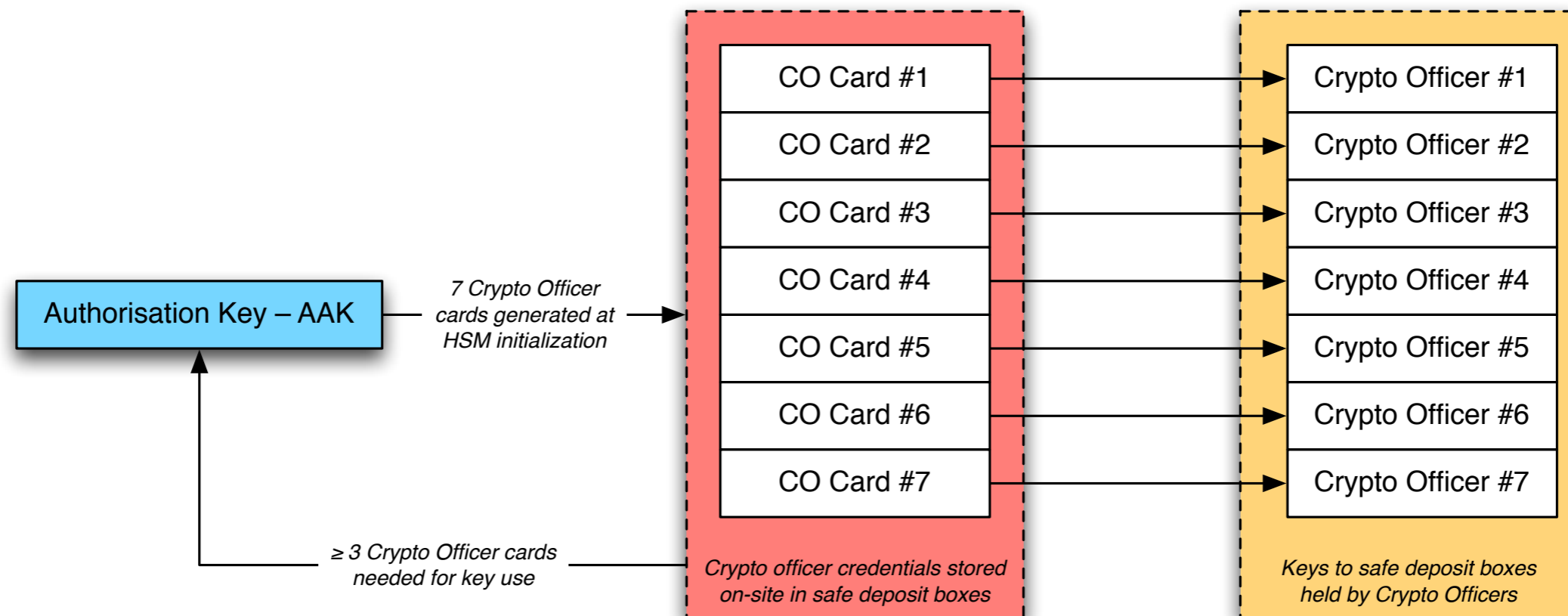

Key Backup

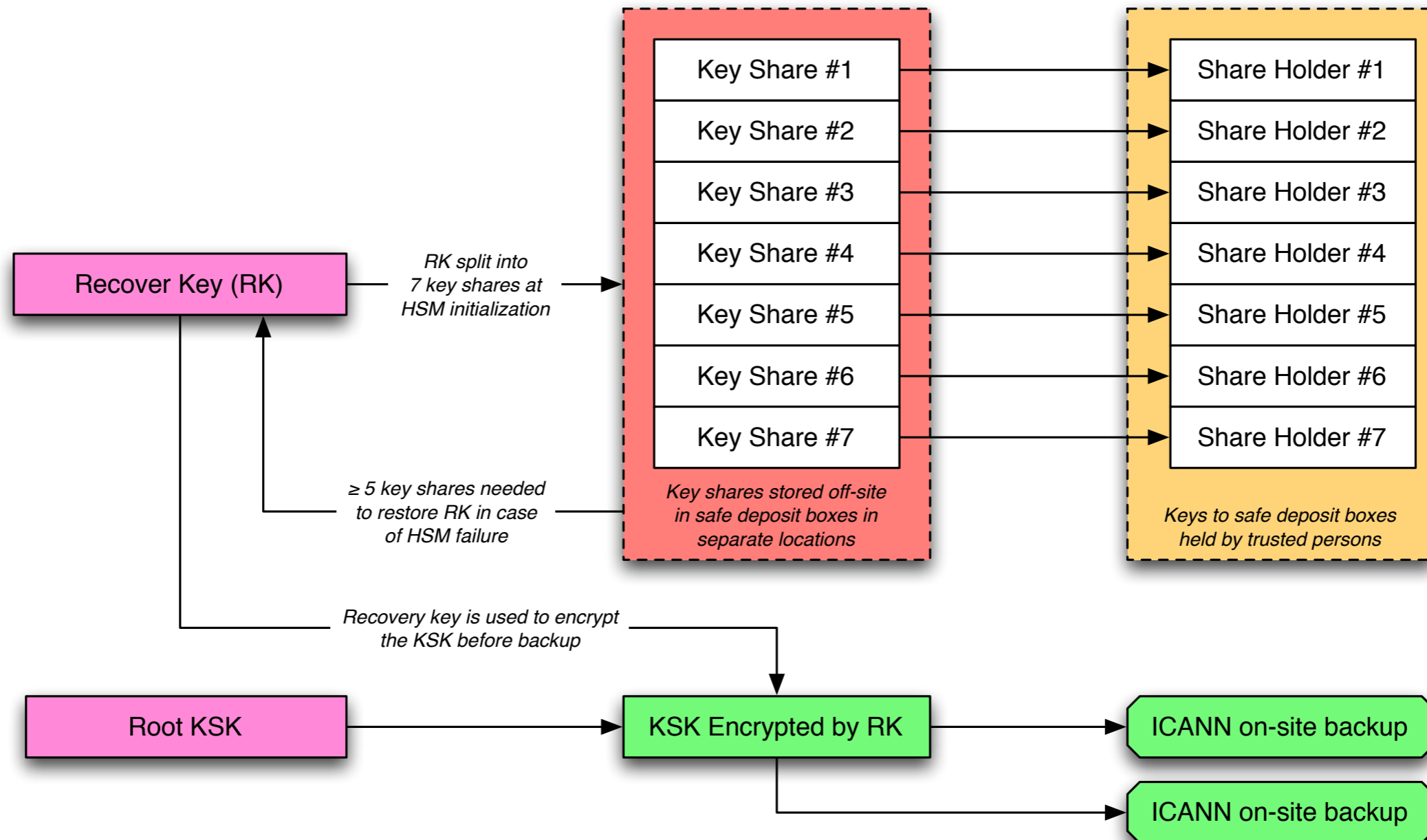

Auditing & Transparency

- Third-party auditors check that ICANN operates as described in the DPS
- Other external witness may also attend the key ceremonies

DNSSEC

Protocol Parameters

Key Signing Key

- KSK is 2048-bit RSA
 - ▶ Rolled every 2-5 years
 - ▶ RFC 5011 for automatic key rollovers
- Propose using signatures based on SHA-256

Zone Signing Key

- ZSK is 1024-bit RSA
 - ▶ Rolled once a quarter (four times per year)
- Zone signed with NSEC
- Propose using signatures based on SHA-256

Signature Validity

- DNSKEY-covering RRSIG (by KSK) validity 15 days
 - ▶ new signatures published every 10 days
- Other RRSIG (by ZSK) validity 7 days
 - ▶ zone generated and resigned twice per day

Key Ceremonies

- Key Generation
 - ▶ Generation of new KSK
 - ▶ Every 2-5 years
- Processing of ZSK Signing Request (KSR)
 - ▶ Signing ZSK for the next upcoming quarter
 - ▶ Every quarter

KSR Processing

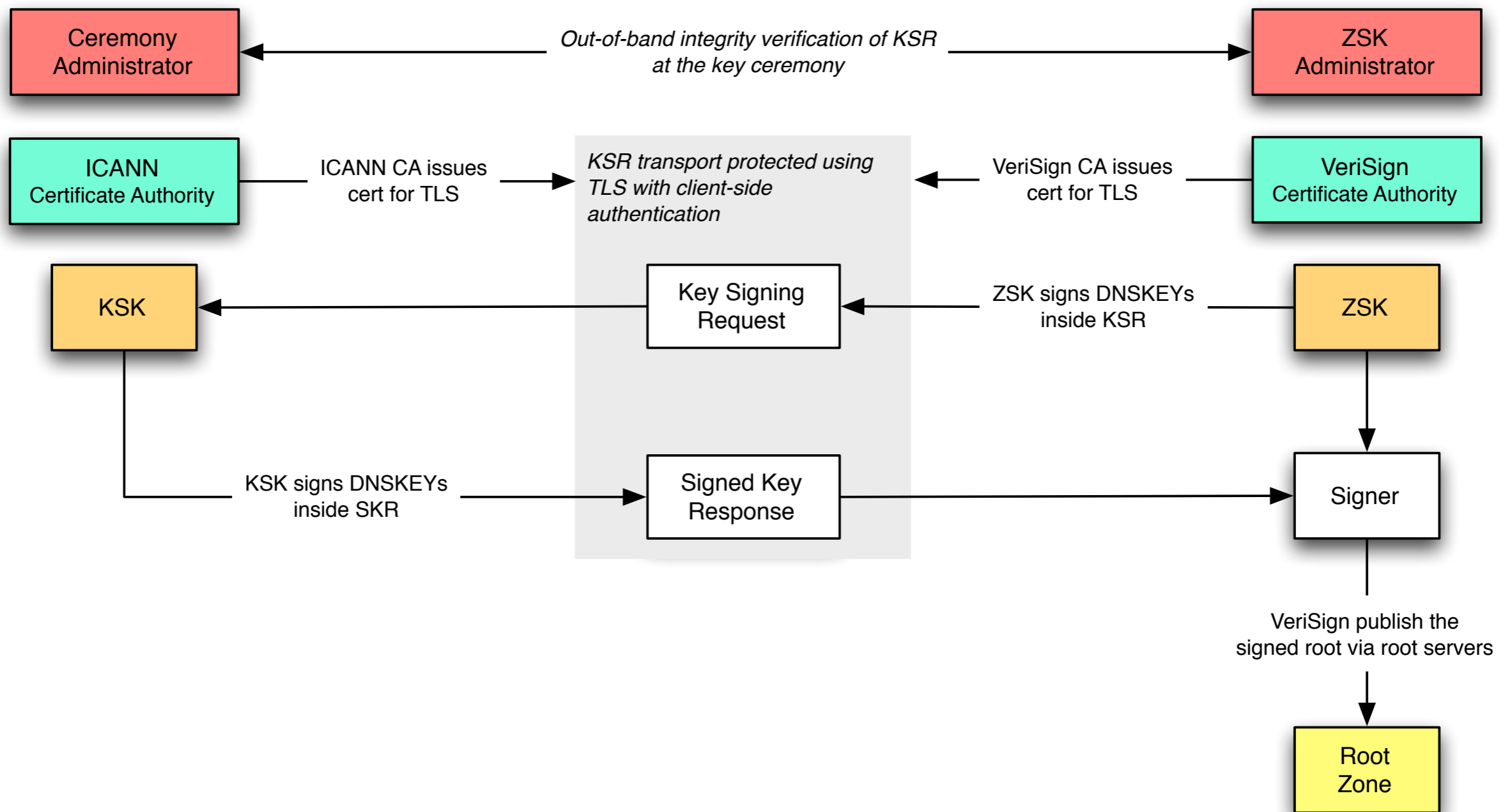

KSR Processing

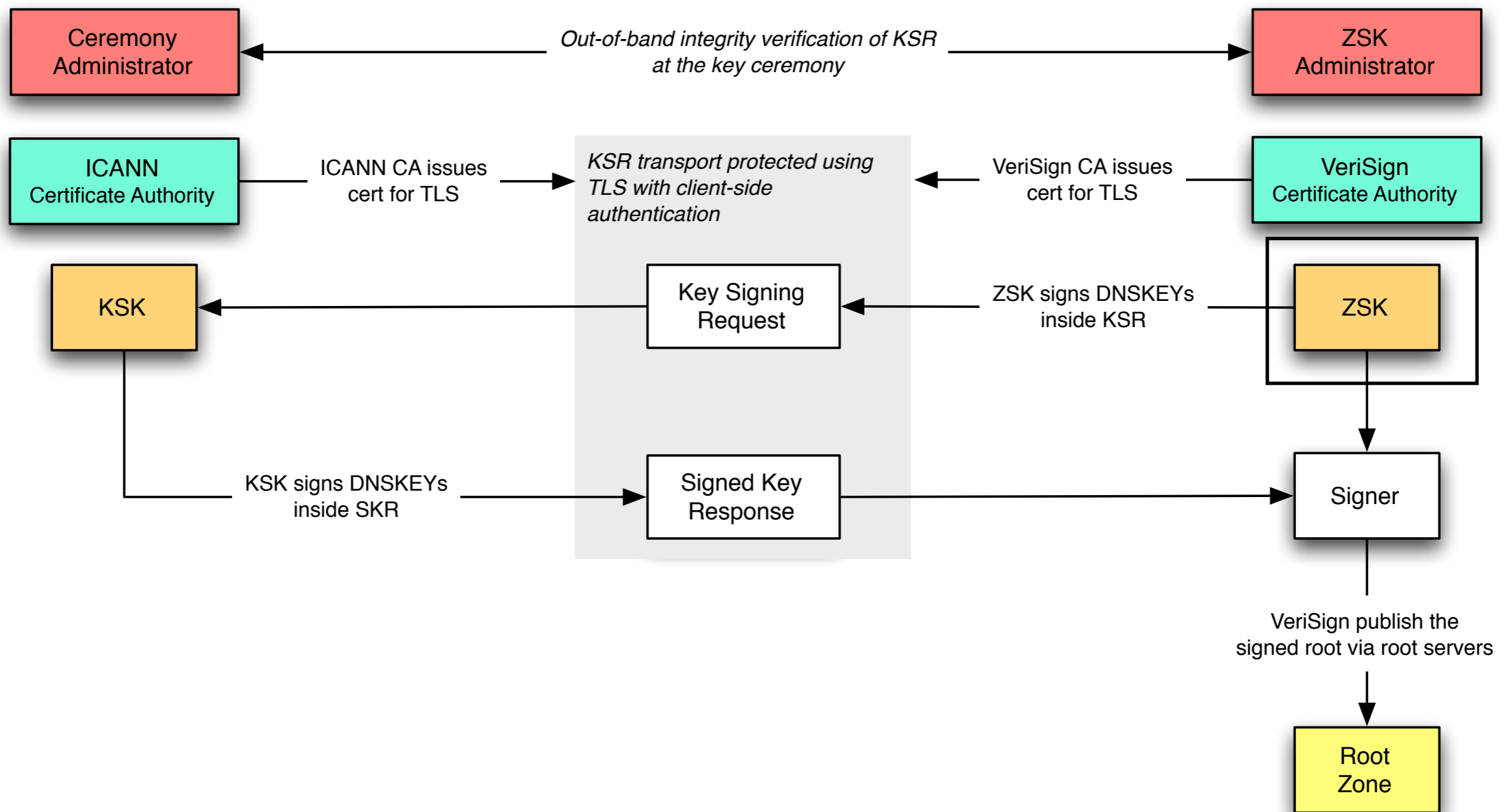

KSR Processing

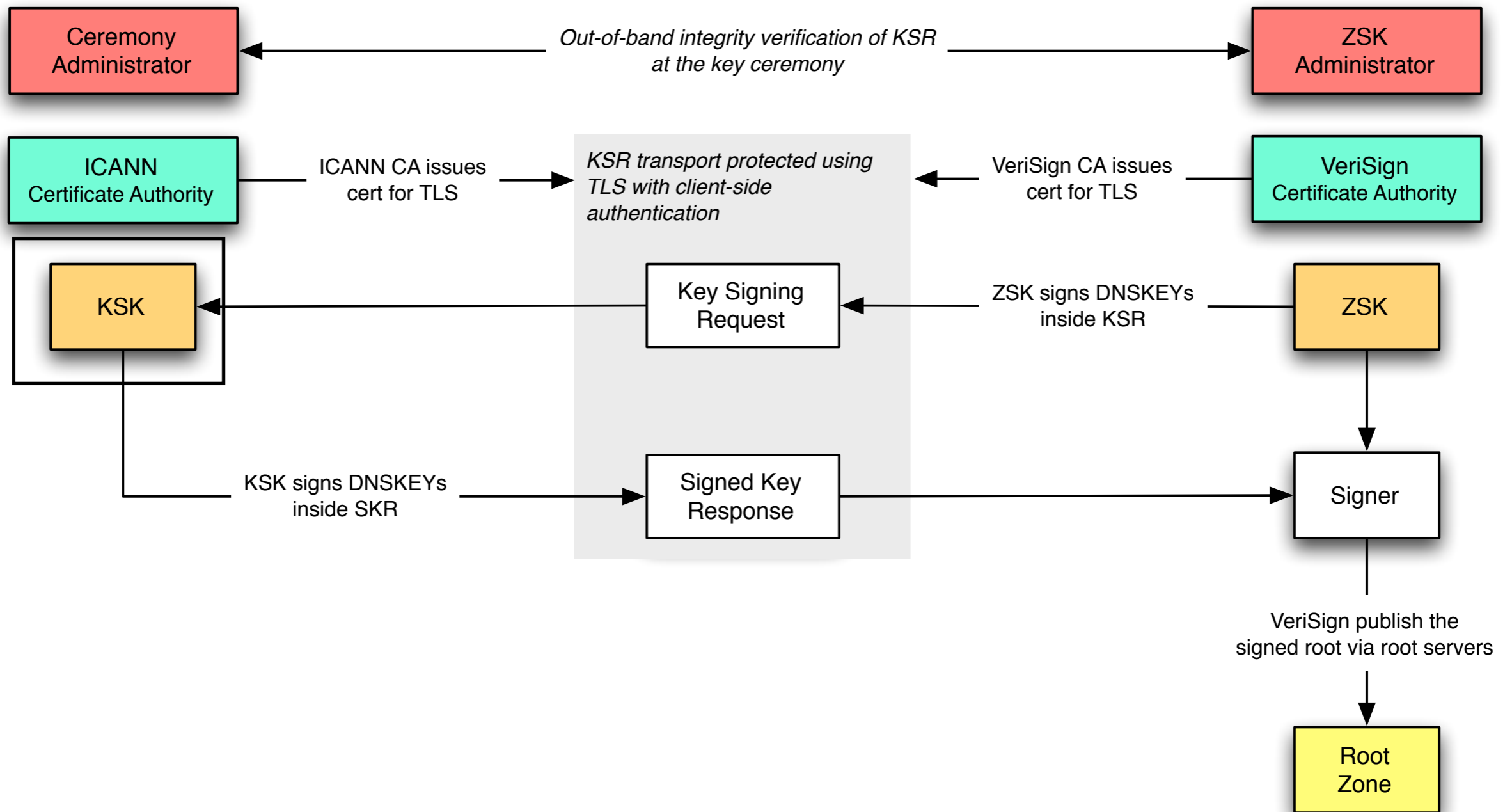

KSR Processing

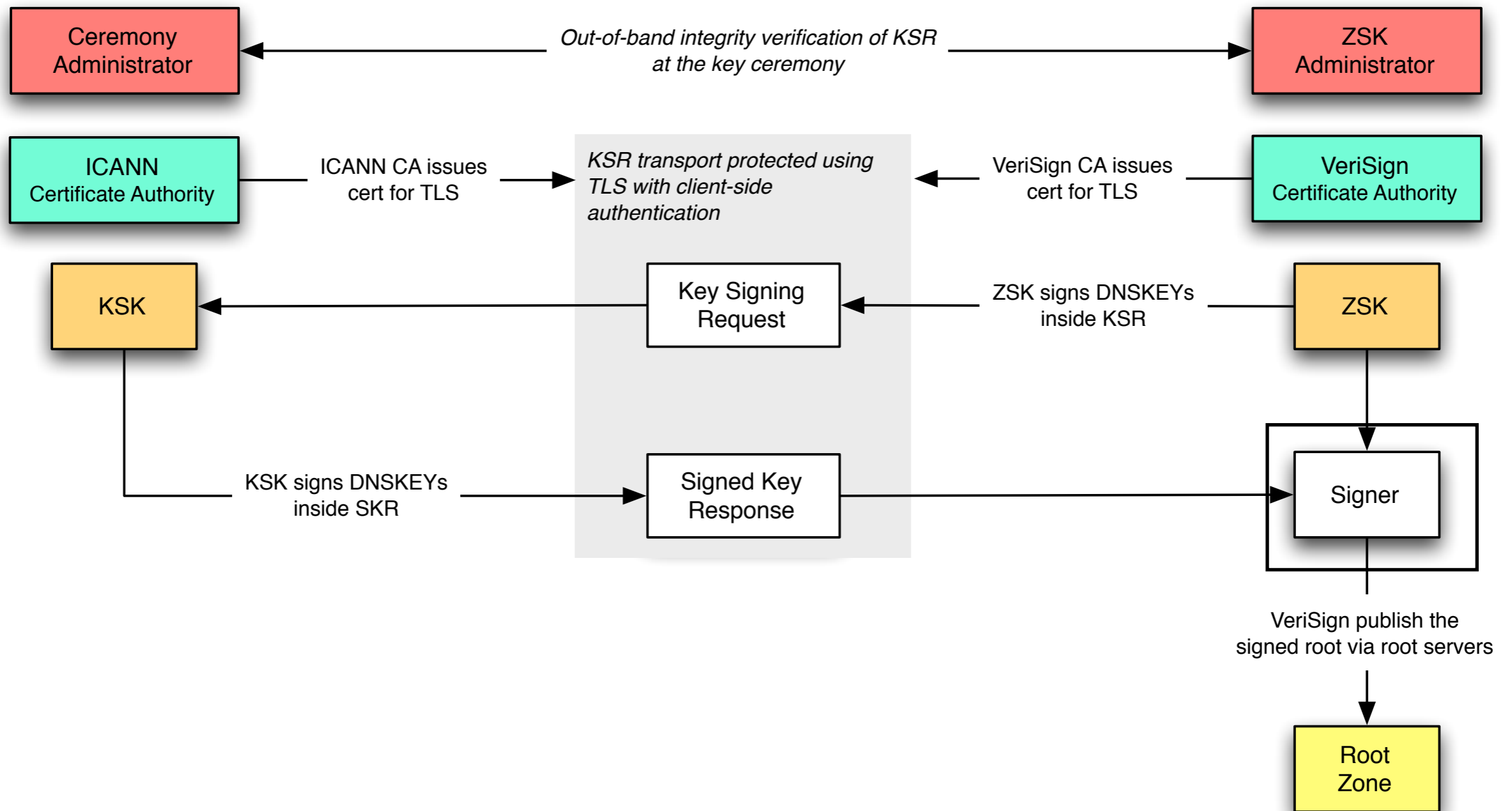

KSR Processing

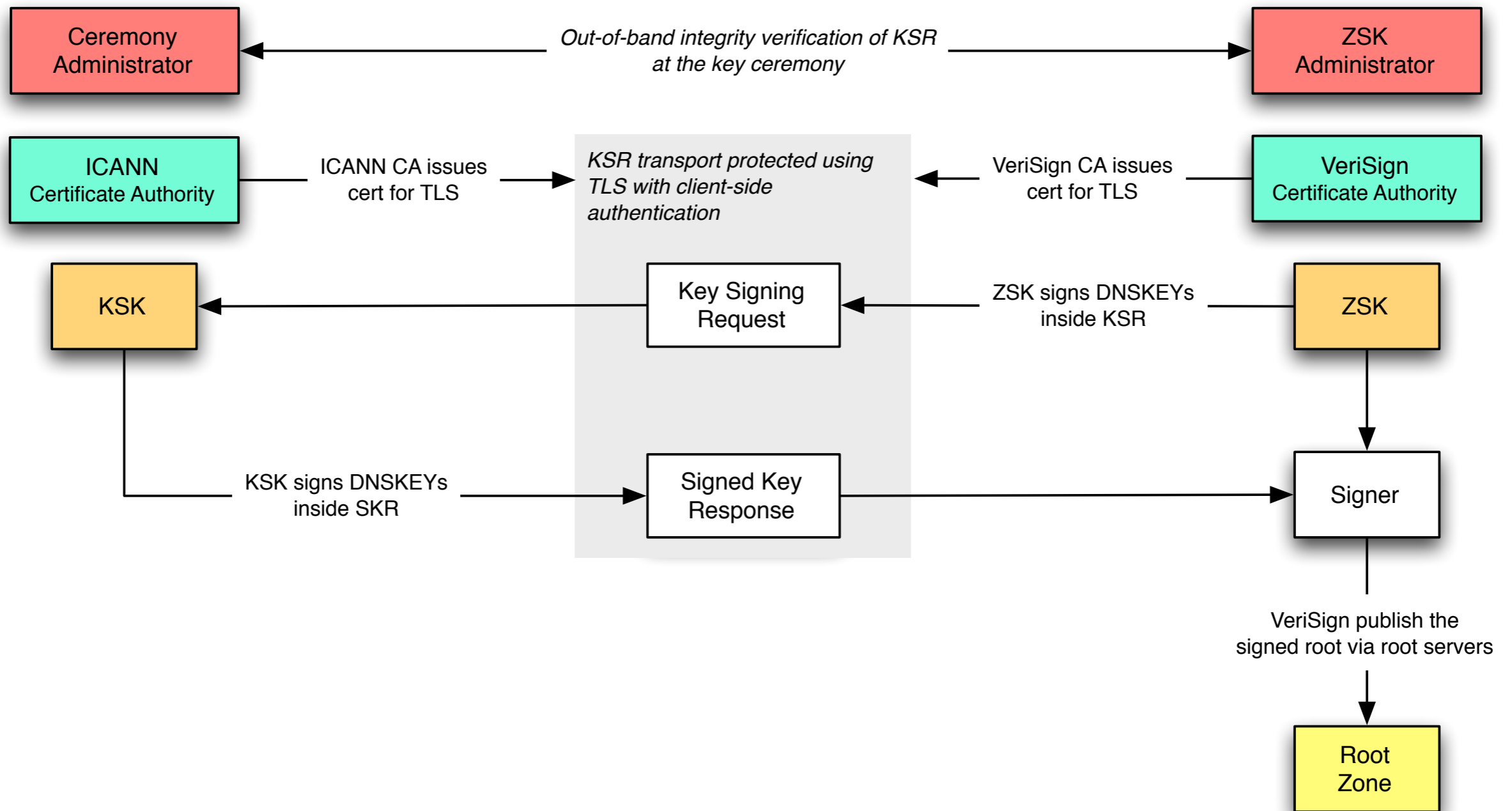

Key Schedule

Key Schedule

Quarterly time cycle is ~ 90 days



Key Schedule

Quarterly time cycle is ~ 90 days

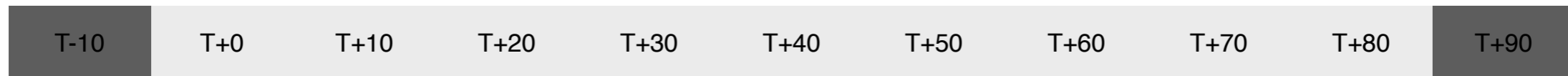

ZSK rollover



Key Schedule

Quarterly time cycle is ~ 90 days



ZSK rollover



Optional KSK rollover



Key Schedule

Quarterly time cycle is ~ 90 days

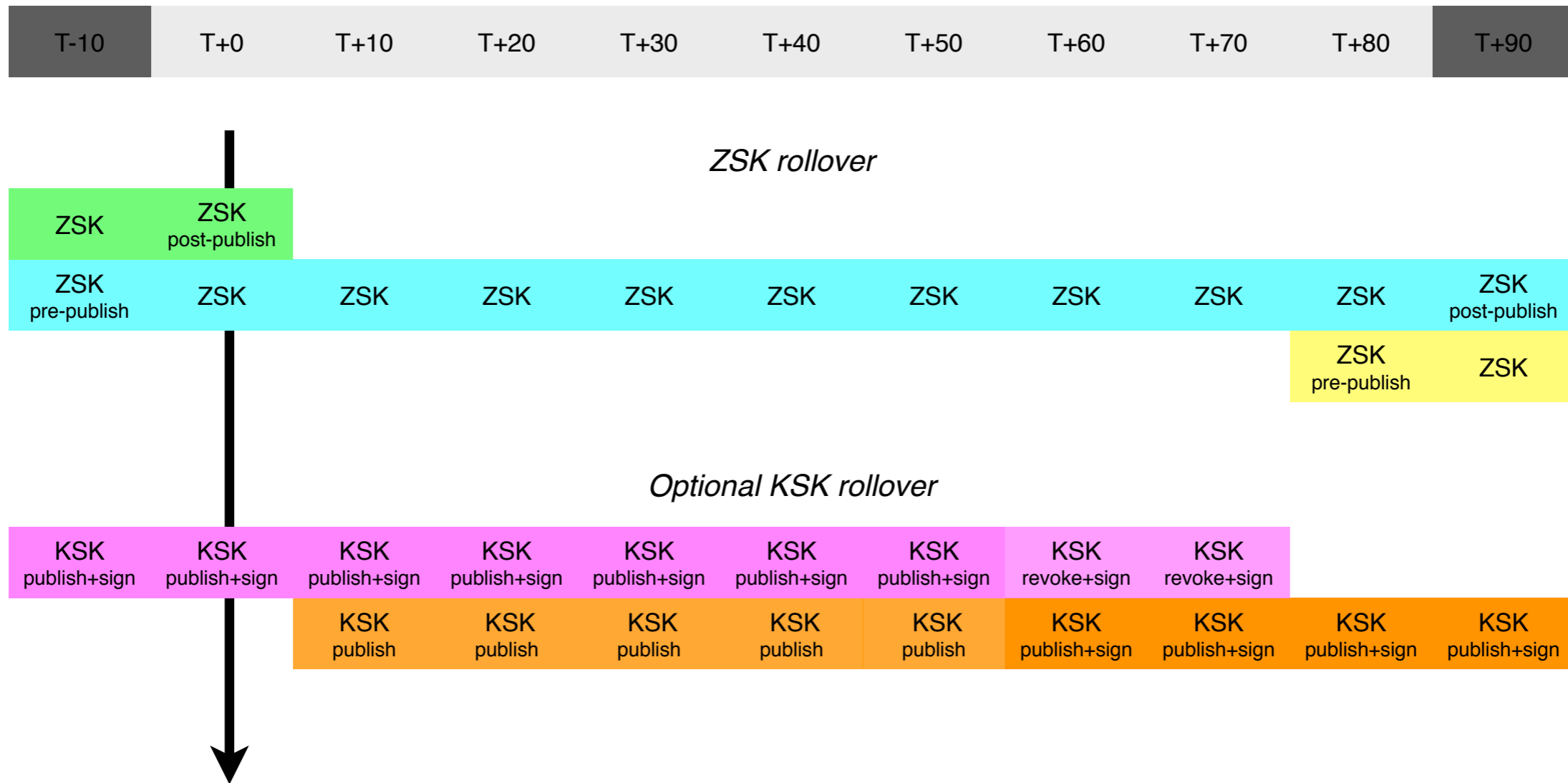

Key Schedule

Quarterly time cycle is ~ 90 days



ZSK rollover



Optional KSK rollover



Key Schedule

Quarterly time cycle is ~ 90 days



ZSK rollover



Optional KSK rollover



Key Schedule

Quarterly time cycle is ~ 90 days

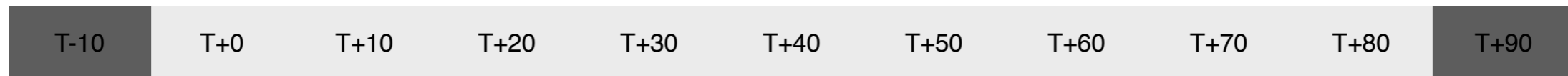

ZSK rollover



KSK removal

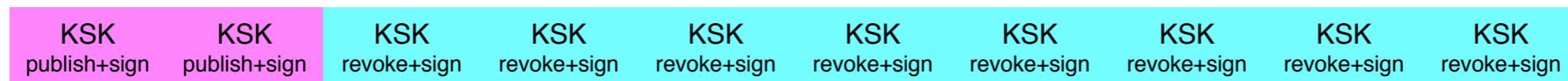

Root Trust Anchor

- Published on a web site by ICANN as
 - ▶ XML-wrapped and plain DS record
 - to facilitate automatic processing
 - ▶ PKCS #10 certificate signing request (CSR)
 - as self-signed public key
 - Allows third-party CAs to sign the KSK
 - ICANN will sign the CSR producing a CERT

Deployment

Goals

- Deploy a signed root zone
 - ▶ Transparent processes
 - ▶ Audited procedures
 - ▶ DNSSEC deployment
 - validators, registries, registrars, name server operators
- Communicate early and often!

Anticipated Issues

DO=1

- A significant proportion of DNS clients send queries with EDNS0 and DO=1
- Some (largely unquantified, but potentially significant) population of such clients are unable to receive large responses
- Serving signed responses might break those clients

Rollback

- If we sign the root, there will be some early validator deployment
- There is the potential for some clients to break, perhaps badly enough that we need to un-sign the root (e.g., see previous slide)
- Un-signing the root will break the DNS for validators

Staged Deployment

Deploy Incrementally

- Serve a signed zone from just L-Root, initially
- Follow up with A-Root
- Then other root servers
 - ▶ M, I
 - ▶ D, K E,
 - ▶ B, H, C, G, F
- Last, J-Root

Deploy Incrementally

- The goal is to leave the client population with some root servers not offering large responses until the impact of those large responses is better understood
- Relies upon resolvers not always choosing a single server

DURZ

- “Deliberately Unvalidatable Root Zone”
- Sign RRSets with keys that are not published in the zone (but with matching keytag...)
- Publish keys in the zone which are not used, and which additionally contain advice for operators (see next slide)
- Swap in actual signing keys (which enables validation) at the end of the deployment process

DURZ

- Deploy conservatively
 - ▶ It is the root zone, after all
- Prevent a community of validators from forming
 - ▶ This allows us to unsign the root zone during the deployment phase (if we have) to without collateral damage

Measurement

- For those root servers that are instrumented, full packet captures and subsequent analysis around signing events
- Ongoing dialogue with operator communities to assess real-world impact of changes

Testing

- A prerequisite for this proposal is a captive test of the deployment
 - ▶ Test widely-deployed resolvers, with validation enabled and disabled, against the DURZ
 - ▶ Test with clients behind broken networks that drop large responses

Interaction with TLDs

DS Change Requests

- Approach likely to be based on existing methods for TLD managers to request changes in root zone
- Anticipate being able to accept DS requests 1-2 months before the validatable signed root zone is in production
- Current topic of discussion within Root DNSSEC Design Team

Communication

Project Web Page

- <http://www.root-dnssec.org>
 - ▶ Status updates
 - ▶ Documents
 - ▶ Presentation Archive
 - ▶ Small collection of links to relevant tools
 - ▶ Contact information
 - ▶ RSS

Communication

with non-technical audiences

- Will reach the non-technical and semi-technical audiences with press releases and other means.
- PR departments with people who know how to do this will be engaged.

Communication

with technical audiences

- Reaching the technical audiences via mailing lists and other means
 - ▶ IETF DNS lists (e.g. DNSOP)
 - ▶ non-IETF DNS lists (e.g. DNS-OARC)
 - ▶ General operator lists (e.g. NANOG)
 - ▶ ...

Draft Timeline

- December 1, 2009
 - ▶ **Root zone signed**
 - Initially signed zone stays internal to ICANN and VeriSign
 - ▶ ICANN and VeriSign begin KSR processing
 - ZSK and KSK rolls
- January - July 2010
 - ▶ Incremental roll out of signed root
- July 1, 2010
 - ▶ KSK rolled and trust anchor published
 - ▶ **Signed root fully deployed**

Deployment Status

25 January 2010

Documentation

- Requirements document posted
- High-Level Architecture, Policy and Practice Statements, Trust Anchor Publication, Deployment documents posted in draft form
- Ceremony, KSK Facility Requirements, Testing documents expected to be posted soon

<http://www.root-dnssec.org>

Testing

- Several rounds of data collection testing by Root Server Operators complete
- Several KSR/SKR exchanges complete
- DURZ vs. Resolver testing complete

DURZ Roll-Out

- L-Root scheduled to start serving the root zone during the posted maintenance window 2010-01-27 1800-2000 UTC

Thoughts?

- Feedback on this proposal would be extremely welcome
 - ▶ Email to rootsign@icann.org

Root DNSSEC Design Team

Joe Abley
Mehmet Akcin
David Blacka
David Conrad
Richard Lamb
Matt Larson
Fredrik Ljunggren
David Knight
Tomofumi Okubo
Jakob Schlyter